

## Drážkovacia fréza s rovnými zubami

**5010**

**Prevedenie:** pájkované doštičky HM

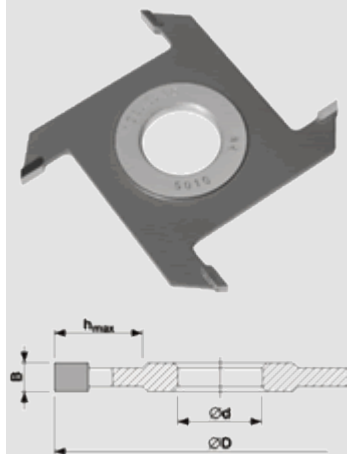

Ø D (mm)	B (mm)	h <sub>max</sub> (mm)	počet nožov	Ø d (mm)	n <sub>max</sub> (min <sup>-1</sup> )
125	4	37	4	30	10 000
125	5	37	4	30	
125	6	37	4	30	
125	8	37	4	30	
125	10	37	4	30	
125	12	37	4	30	7 000
160	6	55	4	30	
160	8	55	4	30	
160	10	55	4	30	
160	12	55	4	30	
160	14	55	4	30	

## Drážkovacia fréza s rovnými zubami a predrezmi

**5011**

**Prevedenie:** pájkované doštičky HM



Ø D (mm)	B (mm)	h <sub>max</sub> (mm)	počet nožov	Ø d (mm)	n <sub>max</sub> (min <sup>-1</sup> )
100	4	25	4+2	30	12000
100	5	25	4+2	30	
100	6	25	4+2	30	
100	8	25	4+2	30	
100	10	25	4+2	30	
100	12	25	4+2	30	
125	4	37	4+2	30	10000
125	5	37	4+2	30	
125	6	37	4+2	30	
125	8	37	4+2	30	
125	10	37	4+2	30	
125	12	37	4+2	30	

160	5	55	4+2	30	8000
160	6	55	4+2	30	
160	8	55	4+2	30	
160	10	55	4+2	30	
160	12	55	4+2	30	
160	14	55	4+2	30	
180	6	65	4+2	30	7000
180	8	65	4+2	30	
180	10	65	4+2	30	
180	12	65	4+2	30	
180	14	65	4+2	30	
180	16	65	4+2	30	

## Drážkovacie frézy s rovnými zubami a predrezmi

### 1150

Prevedenie: pájkované doštičky HM

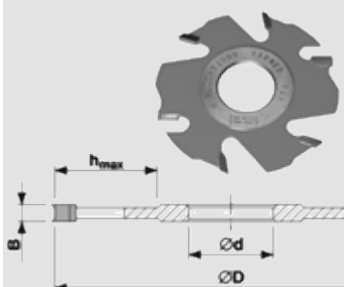

Ø D (mm)	B (mm)	h <sub>max</sub> (mm)	počet nožov	Ø d (mm)	n <sub>max</sub> (min <sup>-1</sup> )
125	4	25	4+2	30	6500 - 10000
125	5	25	4+2	30	
125	6	25	4+2	30	
125	8	25	4+2	30	
125	10	25	4+2	30	
125	12	25	4+2	30	
160	4	37	4+2	30	5000 - 8000
160	5	37	4+2	30	
160	6	37	4+2	30	
160	8	37	4+2	30	
160	10	37	4+2	30	
160	12	37	4+2	30	

## Drážkovacia fréza so šikmými zubami a predrezmi

## 5012

**Prevedenie:** pájkované doštičky HM

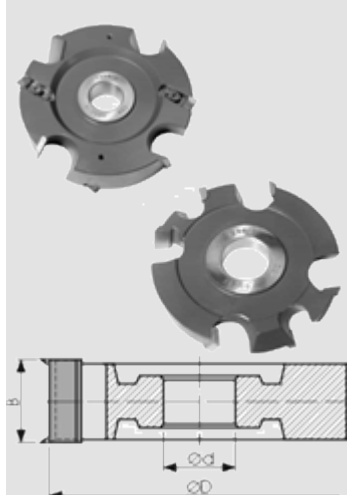

Ø D (mm)	B (mm)	počet nožov	Ø d (mm)	$n_{\max}$ (min <sup>-1</sup> )
125	16	4+1+1 <sup>1</sup>	30	10000
125	18	4+1+1 <sup>1</sup>	30	
125	20	4+1+1 <sup>1</sup>	30	
125	25	4+2+2 <sup>2</sup>	30	
125	30	4+2+2 <sup>2</sup>	30	
125	35	4+2+2 <sup>2</sup>	30	
125	40	4+2+2 <sup>2</sup>	30	8000
160	40	4+2+2 <sup>2</sup>	30	

## Nožová hlava s vymeniteľnými doštičkami a predrezmi

### 3551

**Prevedenie:** axiálne uložené vymeniteľné britové doštičky

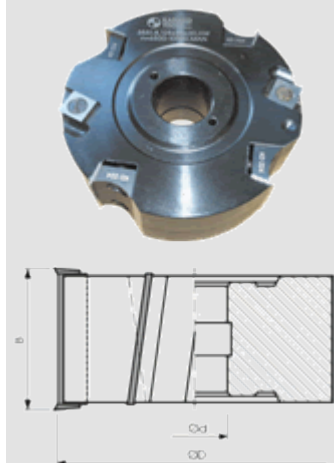

Ø D (mm)	B (mm)	počet nožov	Ø d (mm)	$n_{\max}$ (min <sup>-1</sup> )
125	30	4+2+2	30	8500 - 10000
125	30	4+2+2	30	

## Staviteľná falcovacia hlava

### 3553/S

**Prevedenie:** vymeniteľné britové doštičky

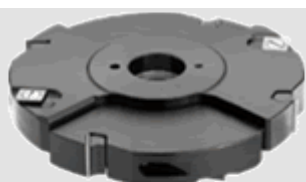

Ø D (mm)	B (mm)	počet nožov	Ø d (mm)	T <sub>max</sub>	n <sub>max</sub> (min <sup>-1</sup> )
160	20,6 - 40	4+4	30	42	8500 - 10000

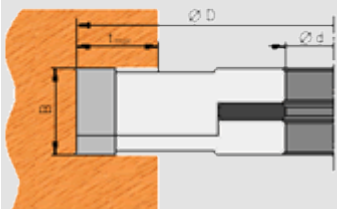

## Fréza čapovacia

### 2850

**Prevedenie:** pájkované doštičky HM  
Max. hĺbka čapu ØD 250 je 95mm

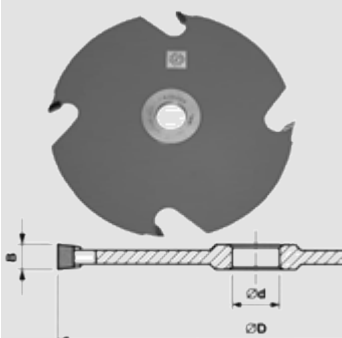

Ø D (mm)	B (mm)	počet nožov	Ø d (mm)	n <sub>max</sub> (min <sup>-1</sup> )
250	8	4	30	3500 - 5500
250	10	4	30	
250	12	4	30	
250	14	4	30	
250	16	4	30	
250	18	4	30	
250	20	4	30	2800 - 4500
277	18	4	30	

## Staviteľný čapovací kotúč

### 2850/S

**Prevedenie:** vymeniteľné britové doštičky  
**Použitie:** k priečnemu obrábaniu dreva

Ø D (mm)	B (mm)	Ø d (mm)	z	T <sub>max</sub>	n <sub>max</sub> (min <sup>-1</sup> )
250	8-15	30	4 + 4	100	3500 - 4500

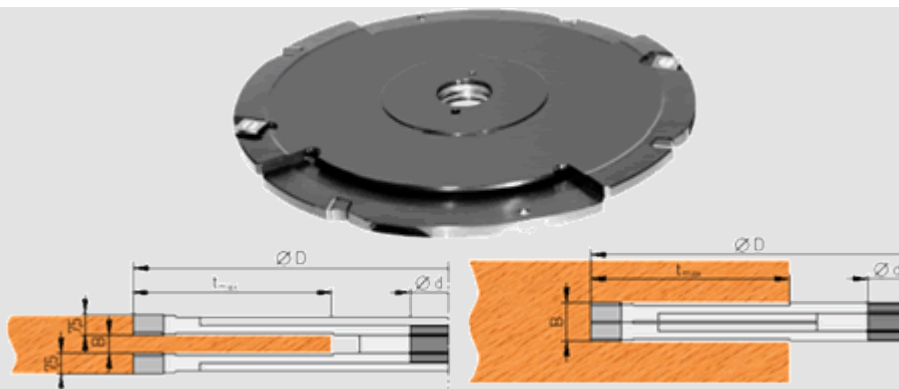

## Falcovacia nožová hlava s VBD + zrážacie a zaoblovacie nože

**3552**

**Prevedenie:** vymeniteľné britové doštičky

- výmenné britové doštičky
- fréza je osadené zrážacími nožami. Možnosť dokúpiť nože R1,5, R2, R3, R4 alebo R5 k zaoblovaniu hrán

Ø D (mm)	Počet nožov	B (mm)	Ø d (mm)	n <sub>max</sub> (min <sup>-1</sup> )
125	4 + 4 + 4	50	40	8500 - 10000

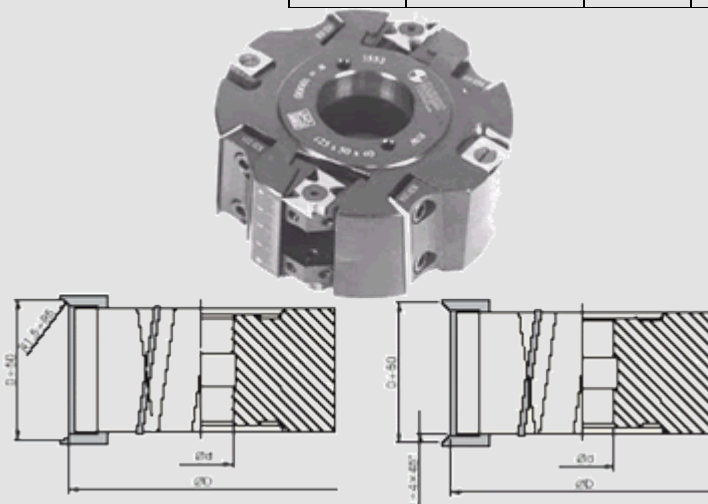

Ceny sú prepočítané konverzným kurzom 1€=30.1260 Sk.